



# HONDA TECH MANUAL GX 120



## HONDA ENGINE RULES FOR 120 HONDA CLASS ONLY

First Issued:  
Updated:

March 30, 1996  
January 2024

*Dave Falini QMA Technical Director*

**UNLESS IT SAYS YOU CAN DO IT, YOU CANNOT DO IT**

- 1) External visual check of engine for required components: Pipe and muffler, shrouds and sheet metal.
  - a) **Exhaust:** All of the exhaust gasses that the engine produces must pass thru the muffler. The Honda muffler shall be removed and discarded. The factory supplied flange may be cut off and used an adapter flange for the new exhaust pipe. An aftermarket flange may be utilized, 0.27" maximum thickness. The transition from the "D" shape and the round ID of the pipe may be blended. There shall not be any steps or tapers in the pipe from the flange to the pipe coupling that the muffler screws into. However, the same diameter tubing may be butt welded together to obtain the desired path and length of the exhaust pipe. The pipe shall be between 20.0 to 26.0 ± 0.06" inches long including the ¾ pipe coupling to attach the Briggs & Stratton 294599 or aftermarket equivalent. The length of the pipe shall include flange and the coupler. If the flange is attached to the pipe at an angle the midpoint shall be the point of measuring. This dimension shall be checked with a small piece of flexible hose about ½ inches in diameter averaging the long measurement and the short measurement.
  - b) **Air Filter:** Any QMA approved air filter may be attached to the outside of air filter adapter. The stock Honda air filter gasket may be used. Outer wear style or equivalent can be used over carburetor only with no adapter We are using "outerwear" to define a style not brandname). The approved air filter adapter may be run with or without an air filter. Any air filter may be used with adapter as long as there are no device(s) may be used inside the air filter or adapter that will alter the airflow into the carburetor; however, the anti-deformation spring that is supplied with the foam filters may be used.
    - (1) Air cleaner adapter will be maximum ID 2.250" and a maximum of 1.375" long in length, flange thickness 0.395" max. flange ID 1.000" minimum hole size straight walled, flat bottomed and parallel with carburetor using existing air cleaner mount holes.

**\*UPDATE\*** Air filter cup flange thickness maximum is now .395"

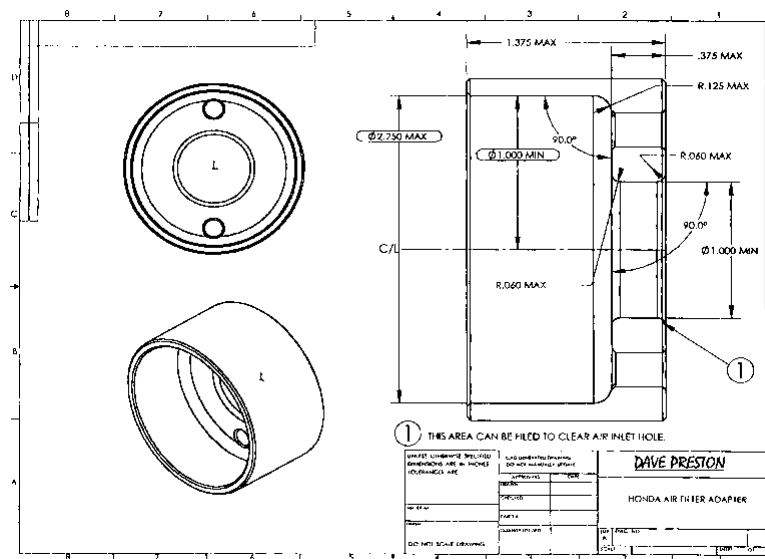

- 2) Any type throttle linkage may be utilized. Carburetor will be unaltered with the exception of the black plastic piece on upper end of throttle shaft. This is the only part in the carburetor that can be altered.
  - a. Material may not be added to throttle stop area of black plastic piece or carb body.
  - b. Rear mounting brackets for Honda fuel tank may be removed.
  - c. The starter cup that is behind the flywheel retaining nut can be cut away to leave only the flat washer back piece that retains cooling fan.
  - d. The keyed end of the ring gear shaft may be shortened, drilled and tapped or machined for snap ring.
  - e. All threaded holes may be Heli-Coiled but are not allowed to be relocated.
  - f. Honing and deglazing of the bore is allowed.
  - g. Lapping the valves is allowed.
  - h. Oil drain back hole between lifters may be enlarged
  - i. Aftermarket drain plug and fill plugs may be used
  - j. Aftermarket valve cover gaskets is legal.
    - i. One gasket only
    - ii. No silicone on gasket surface.

- 3) **Blocking Air Flow:** No device may be used that will/or appear that it may impede airflow into the engine cooling system. This may require that the engine be run at a speed above idle by the tech personnel at the scale after the car has qualified or raced.

## **CARBURETOR**

### **GX160 CARBURETOR (BE54D) (BE65B) and (BE65Q) MAY BE USED IN HEAVY HONDA ONLY (SEE GX160 MANUAL FOR CARB SPECS)**

#### **1) Remove Carburetor:**

- a) Check for restrictor, if applicable, and placement. Restrictor must be installed between carburetor and carburetor insulator with stock Honda gasket on each side of restrictor. Only stock Honda insulator gasket between black plastic insulator and head. Air passageway in insulator will not be altered in anyway. All Junior Honda class engines must use the blue QMA approved slotted plate only. Failure to use proper restrictor plate, alteration of restrictor plate, or improper installation of plate in designated classes is cause for immediate DQ and all applicable suspensions will be applied.
  - b) Restrictor Plates: All restrictor plates must be measured with Pin Gauges.
    - Novice Restrictor (Honda)- Red plate with single hole .3125" Max– Use a .3135- diameter no-go pin gauge.
    - Jr. Honda (Honda)- Blue plate with single hole .4375" Max– Use a .4385- diameter no-go pin gauge.
    - Red and Blue QMA restrictor plates will be recommended. All blue restrictor plates must be dated 06/09 or newer.
    - The use of POWRI or USAC restrictor plates are allowed but still must meet the QMA no/go gauge hole specifications as outlined above.
    - (If the restrictor plate does not have a date on it confiscate the plate. If the plate is not legal DQ and any applicable suspensions will apply).
  - c) Restrictors will be checked by NO-GO gauges.
- 2) Check for any alterations or worn parts that would allow additional air into engine: holes, slots, perforations, spacers, loose bolts, warped flanges etc.
  - 3) Carburetor identification number: BE 60 B, BE 60 R, BE99A, BE99L and BE99M
  - 4) Check carburetor for alterations. Upper choke shaft hole may be sealed with silicone type sealer.
  - 5) Two stock Honda intake gaskets may be used between Carburetor and plastic insulator.
  - 6) Carburetor Bore:
    - Intake end: maximum diameter 0.950"
    - Throttle end: maximum diameter 0.632"
  - 7) Carburetor venturi bore and nozzle height:
    - a) BE60B, BE60R, BE99A, BE99L and BE99M: Shall be checked with a no-go gauge 0.452" diameter with a 0.429" flat. If the gauge passes through, then the carburetor shall be deemed illegal. Further venturi diameter check with a 0.456"- no-go gauge will determine the item for DQ.
    - b) The butterfly screw, the butterfly, and the throttle shaft may not be removed from the carburetor. Any evidence of tampering will be a disqualification and suspension.
    - c) Pilot Jet 0.015" No-Go Gauge
    - d) Decimal equivalents of numbered size drills chart on page 12

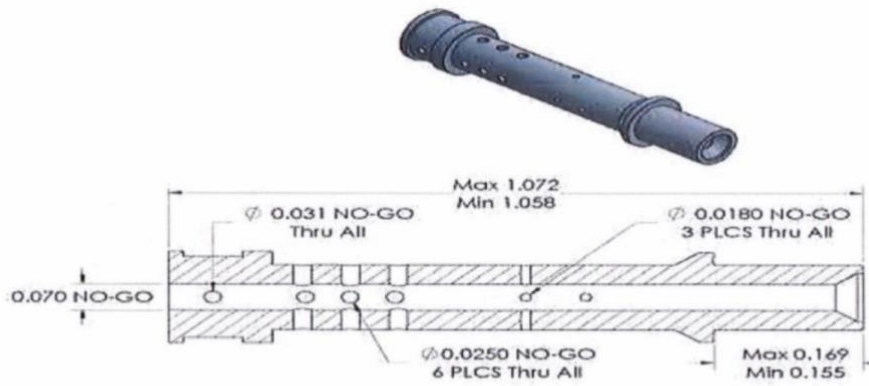

GX120 Emulsion Tube

**ENGINE COOLING SHROUDS**

- A. All pieces of the stock engine-cooling shroud must be properly installed.
- B. There must be no addition or subtraction of any material from the shrouding except for the covering of the switch hole (any material). Starter cup may be altered to be used as washer retainer for the cooling fan.
- C. Fan shroud may be repainted any color. All other shrouds must remain as produced by Honda.

Zero Dial Indicator after exhaust bump. (0.050) ref.

Maximum valve lift will be checked from the top of valve spring retainer. Valves may be adjusted to zero clearance or shims may be installed to create zero clearance. This may dictate making special shims, as it is difficult to insert feeler gauge blades so as not to interfere with indicator contracts on retainer.

**Valve lift:**

- Intake: 0.245" maximum
- Exhaust: 0.255" maximum



**CYLINDER HEAD, HEAD GASKET, VALVES, SPRINGS**

- A. Remove cylinder head.
  - Head gasket thickness: 0.040" minimum thickness of inner rim.
  - Head gasket thickness UT-3 engine: 0.008" minimum.
- B. Remove valves: The use of valve seals is legal on the intake only.
- C. Honda UT3: .030" max shim allowed on intake.
- D. Honda UT3: may use one shim only (can not use valve seal and a shim)

## VALVE SPRINGS

- A. Valve springs will be stock Honda PN 14751-ZF1-000 or PN 14751-ZE1-000.
- **No modifications allowed.**
- B. Use known Honda spring for comparison. Wire diameter 0.071" and 0.079"
- C. Stacked length will be: 0.394" maximum



## ROCKER ARMS - PUSH RODS – STUDS

Rocker arms will be stock Honda and will not be altered in any way. Rocker arm studs will be stock Honda. They or their mounting position may not be altered in any manner. No heli-coiling of mounting holes. No bending of studs. Push rods will be stock Honda and will not be altered in any way. Push rod maximum length 4.803 inches.

## VALVES

- A. Check valves for weight. Valve seating surface must be factory ground to a single angle only, 45 degrees. There will be no other angles ground on any part of valve. **Valves must not be polished, lightened or altered in any way.**
- B. Valve Weight:
- Intake: 18 grams minimum
  - Exhaust: 16 grams minimum
- C. UT-3 Valve Weight:
- Intake: 21 grams minimum
  - Exhaust 16 grams minimum
- D. Valve Stem diameter intake 0.216" ± .001" exhaust 0.214" ± 0.001"
- E. Valve Head diameter intake 0.978/0.986 ± 0.002" exhaust 0.744/0.752" ± 0.002"

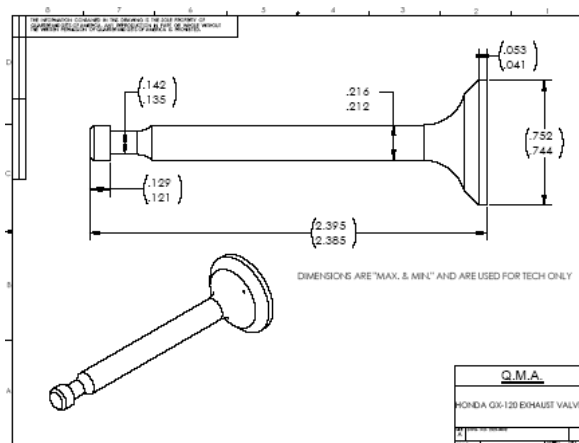
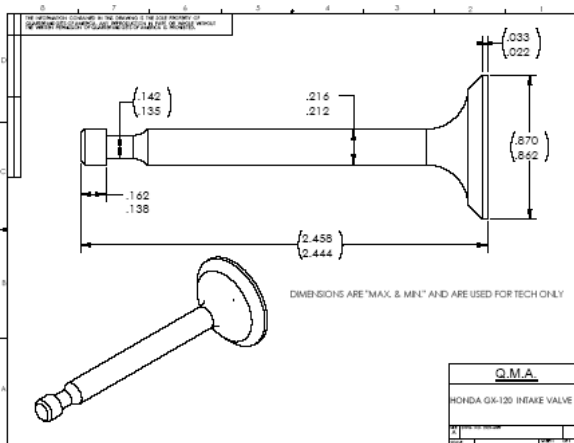

Note: UT-1 (Current 120) ex valve part # 14721-ZF0-000 – Retainer # 14773-ZE1-000 and lash cap # 14781- ZE1-000 must be used in combination. UT-2 (New 120) ex valve part # 14721-Z4H-00 and –Retainer #14771- ZE1-000 must be used in combination (no mixing of old and new style parts) New style ex valve 14721-Z4H-000 measures 2.470 overall length

## **HEAD**

Cylinder head will be in “as cast” and in factory machined condition and there must be no addition of metal or any other substance to the inside or outside of the cylinder head except the head gasket surface may be milled. Honda Racing HPD B000 and B100 may be used on UT1 and UT2 only. Inspect the head for any material removal or addition. Head gasket surface non-tech item. The only TKI head allowed on UT1 and UT2 engines is the HPD B000/B100 head. The UT3 engine may run an optional shim under the intake spring up to .030 in thickness.



(Japan heads may be identified by the casting mark shown in photo above)

Thickness of head. This will be measured from valve cover surface to head gasket surface at the side at a position in line with upper intake & exhaust flange bolt.

- UT1/UT2 Minimum 2.911”
- Honda Racing HPD heads have a minimum thickness of 2.900 measured as above.
- UT3 Minimum 2.938”

## **INTAKE AND EXHAUST PORTS**

- A. Ports will be “as cast” and in factory machined condition and there must be no addition or subtraction of metal or any other substance to the inside or outside of the cylinder head.
- B. No alterations of any kind to be made to the intake or exhaust port.
- C. This includes any grinding, polishing, etching, sand blasting or glass beading to interior surface.
- D. Valve seats must be a stock single 45-degree angle. Multi angle valve seats are not permitted. Valve seats must not be replaced.
- E. Intake and Exhaust ports at valve: UT1 and UT2:

Intake:	maximum 0.753”	minimum 0.745”
Exhaust:	maximum 0.675”	minimum 0.665”

UT3:

Intake:	maximum 0.916	minimum 0.906
Exhaust	maximum 0.678	minimum 0.668

- F. Measurement from head gasket surface to top of valve guide:

Intake	maximum 0.925
Exhaust	maximum 0.925

**Note: Cleaning of the combustion chamber or changing the finish of such chamber is illegal.**



## ENGINE BLOCK

Honda UT1, UT2 or UT3 block must be used and in “as cast” and factory machined with the exception of the deck surface, that may be machined to obtain proper deck clearance for the piston.

- A. Cylinder bore will be 2.366” maximum. NOTE: All measurements taken at near the top of bore or very bottom of bore.
- a. **“Wear Limits/Parts Out of Service”** QMA reserves the right to confiscate 120 Honda engine parts deemed illegal or at QMA maximum wear limits. EXAMPLE: Cylinder Bore will be 2.366 Max. All measurements taken at top of bore or very bottom of bore parallel to crank, 90 degrees from crank. Any cylinder block that has one measurement over QMA maximum wear limits will be taken out of service. If no measurements exceed QMA maximum wear limits the part of block will not be confiscated. Handler has the right to have confiscated parts returned to them but will be rendered unusable.
- B. Removal of rear gas tank brackets is permitted
- C. Governor system may be removed in its entirety. Governor arm and shaft may be removed, and the hole plugged. The low oil sensor may be removed and the hole in the block plugged.
- D. Addition of brackets, fittings etc. to accommodate throttle linkage, tachometer, temperature gauge is allowed.
- E. Cylinder Block deck surface non tech
- F. Check bore: 2.366” maximum
- a. **NOTE: All measurements taken at top of bore and very bottom of bore. Do not use calipers, use only inside and outside micrometers to measure the bore.**
- b. Machined surface of block down to thrust face of cam boss: 3.226” minimum 3.240” maximum
- c. Machined surface of block down to bearing face: 3.427” minimum 3.442” maximum
- G. Check stroke: UT-2 1.659” Maximum 1.640” Minimum  
UT-3 1.724” Maximum 1.704” Minimum
- a. Measure amount that piston is up or down from head gasket surface at T.D.C. This will be measured at edge or highest part of piston, not in center or relieved area on UT1 and UT2 engines. UT3 engine will be measured from the machined spot face in the center of the piston. This dimension will be:
- 0.000” Max. – NO PISTON POP UP
- b. Install degree wheel on flywheel. Install pointer in order to read degrees. Locate accurate T.D.C. This should be done with a positive stop type fixture and not established with indicator alone.

## CAMSHAFT

- Cam will be checked with indicator reading off the top end of tappets, which will provide zero clearance. The inverted radius of the top of the tappet presents some problem to get accurate readings and to prevent binding of indicator stem. Indicator holder and positions are very critical in this operation.
- Zero indicator on base circle of cam. Be sure that compression release does not affect zeroing exhaust indicator. (Zero dial indicator after exhaust bump) ref.
- Turning engine in normal rotation, clockwise facing flywheel, take reading at specified opening. Readings must fall between specified degrees on the following chart.
- One profile check point on intake and one profile check point on exhaust may be out of spec, with the exception of the maximum camshaft lift. Maximum camshaft lift cannot exceed maximum spec.

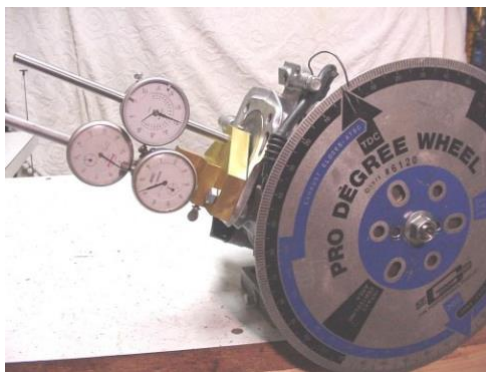

**CAMSHAFT: PROFILE LIMITS**

### Intake Degrees

0.050" 10 ½ - 14-1/2 ATDC  
0.100" 26 ½ - 30-1/2 ATDC  
0.150" 44 - 49-1/2 ATDC  
0.200" 71 - 76 ATDC

### Exhaust Degrees

0.050" 206 - 210 ½ BTDC  
0.100" 189 - 193 ½ BTDC  
0.150" 170 - 174 ½ BTDC  
0.200" 144 - 148 BTDC

### MAX LIFT

0.227"  
0.200" 135-141 ATDC  
0.150" 162 - 167 ATDC  
0.100" 180 - 185 ATDC  
0.050" 197- 201 ATDC

### MAX LIFT

0.229"  
0.200" 69 ½ - 74 ½ BTDC  
0.150" 43 - 48 ½ BTDC  
0.100" 24½ - 29 ½ BTDC  
0.050" 8 -1/2 - 12 ½ BTDC

### FLYWHEEL, FAN AND IGNITION SYSTEM

*Caution should be used when removing flywheel. Do not hit with hammer or other heavy objects. Service manual show flywheel to be removed with commercially available 6" puller. Another method is inertia type knocker that threads onto crankshaft end.*

- A. Use a suitable automotive timing light to check timing at a rotational speed of more than 800RPM. 22.5 degrees BTDC maximum for UT1/UT2. The UT-3 engine must be no more than 20.5° @ more than 800RPM
- Magnet and its position may not be altered in any way.
  - Magnet retaining screw may not be altered in any way. Screw may not be replaced with larger or smaller screw. No heli-coiling of mounting hole.
- B. All of the nylon blades must be present on the cooling fan.

### IGNITION SYSTEM

The transistorized magneto ignition is fixed at 20 degrees BTDC. Firing must not exceed 22.5 degrees BTDC for UT1/UT2. Firing must not exceed 20.5 degrees BTDC for UT3. Offset flywheel key is allowed. Either Honda or offset key must be used. Flywheel may also be lapped.

### PROCEDURE FOR CHECKING TIMING

- A. With degree wheel and pointer installed use the positive stop method to find exact TDC
- B. Use a suitable timing light connected to the spark plug wire, with spark plug used in motor. Using a drill, with the appropriate drive connection to the flywheel nut and rotate engine in clockwise direction to a rotational speed of 800 RPM or more.
- C. Energize the timing light and observe on the degree wheel to see what the timing is. It must be 20.5 degrees BTDC UT3 or 22.5 degrees UT1 and UT2 or less for the ignition timing to be legal.

UT1 or UT2: Black only

UT3: Green (light or dark) only.





- Flywheel weight will be: 1550 grams minimum UT1/UT2. UT3 flywheel minimum is 1525 grams

Flywheel diameter

- Magnet area: 6.285' minimum
- Material removal not permitted.

- A stock Honda spark plug cap, (wire end and resistor), must be used.
- Any automotive type spark plugs with 3/4" reach maximum is allowed.
- Ignition coil air gap is no longer a tech item. Stated dimensions are recommended for safe operation will be: 0.008" minimum - 0.024" maximum.
- No plug-indexing washers allowed.
- If temperature sensor is used under spark plug, factory washer may be removed.

### **GEAR BOX AND RING GEAR**

- Gear box may not be altered in any way. May be rotated to desired position.
- Ring gear may not be altered in any way with the exception of the keyed end of shaft that may be shortened, drilled and tapped or machined for snap ring groove. No other machining, drilling, grinding etc. to ring gear. Keyway may be cut deeper.
- Ring gear may not be altered in any way including polishing or use of any compound or abrasive on gear shaft where bearings ride.
- Two gaskets maximum between gear box halves.

### **CRANKCASE COVER**

Remove crankcase cover.

- Cover must be "as cast" and in factory machined condition and there must be no addition or subtraction of metal or any other substance to crankcase cover.
- Crankcase cover gasket must be stock Honda. Only one gasket may be installed with a maximum thickness of 0.025".
- Critical dimensions are - thrust face of camshaft holder and position of crank bearing. Place a straight edge over crank bearing and cam boss thrust face. These surfaces should be level. Maximum tolerance will be  $\pm 0.005$ ". There will be no alterations to crankcase cover. This includes any alteration to crank bearing and camshaft holder position and height in an attempt to alter valve timing.

### **PISTON - WRIST PIN AND PISTON RINGS**

Remove rod and piston – triangle or boss on top of piston must point toward push rods - piston, wrist pin and rings must be absolutely stock and not altered in any manner.

TIER III- Round Boss

OLD STYLE- Triangle

## **PISTON NOTES**

Piston will be stock Honda standard size and will not be altered in any way.

- A. Oversized pistons must not be used.
- B. All three piston rings must be used and installed properly.
  - *Top ring*: Chrome compression ring installed with “N” or “T” on rail up. Thai rings are marked R. No expander under ring.
  - *Middle ring*: Oil scraper ring installed with “N” or “T” on rail up. Thai rings are marked R. No expander under ring.
  - *Bottom ring*: Three (3) piece oil rings are allowed. Check oil ring expander for alterations that will alter ring tension (cutting ends of expander etc.)
- C. Piston may not be knurled, grooved or coated.
- D. Piston weight: 106 grams minimum.
- E. Total Piston weight: With rings, pin, and clips - 118 grams minimum.
- F. Total Piston weight with rings, retainers, complete with rod, pins and bolts 263 grams minimum.
- G. See drawing for dimensions

## **RINGS OLD STYLE**

- A. A. Must be stock Honda rings with stock size and configuration. Compression and scraper rings may not be collapsed in groove.
- B. B. No decreasing of ring tension by heating, machining or any other means.
- C. F. Ring thickness:

### **OLD STYLE:**

Compression: 0.056” min.  
Scraper: 0.056” min.

### **TIER III:**

Compression: 0.036” min.  
Scraper: 0.036” min.

Oil Ring: 3 piece lower 0.095” min. 1 piece 0.097” min.

## **WRIST PIN**

Stock Honda wrist pin and retainer

OD:	0.511 ref. +/-
Length:	1.854” + 0.010”
ID:	0.354”
Weight:	23 grams minimum



## **CONNECTING ROD**

Stock Honda rod with no alterations, except the big end of the rod may be honed for clearance.

- A. Connecting rod big end size: 1.021” minimum - 1.0285” maximum
- B. Pin end bore is 0.5111 ref.
- C. Length from bottom of pin bore to top of big end bore will be:

- 2.111" maximum      2.101" minimum

- D. Rod weight with bolts: 118 grams
- E. No oil grooves on bearing surface of either end.

## **CRANKSHAFT**

Stock Honda crankshaft with no alterations.

### ***Notes:***

- A. No removal or addition of any metal from or to the crankshaft is allowed.
- B. No balancing of the crank is allowed.
- C. No oil grooving is allowed on the crank journal.
- D. Camshaft drive gear should not be removed.
- E. Keyway location must not be altered in any manner
- F. Measure thrust to crank gear side: 3.340" minimum
- G. The only cleaning method allowed is on the flywheel side of crankshaft for the purpose of removing calcium, rust etc. from the exposed end of the crankshaft. This is permitted only from the seal groove out to the end of the thread of the crankshaft where the flywheel bolts on. Only a wire wheel may be used in the cleaning process. The use of Scotch brite, sandpaper or any other compounds or abrasives is illegal. No material may be added or removed from crankshaft. Crankshaft main journal at flywheel and gearbox ends may not be altered in any way. Heat treat rings on splined end of crank is no longer a tech item as long as crank still makes spec and has not been modified. Governor drive gear is optional (may be removed).

## **CAMSHAFT**

Camshaft must be stock Honda with no alteration of any kind.

### ***Notes:***

- A. There will be no additions to or subtractions from any part of the camshaft.
- B. Compression release will remain intact and unaltered.
- C. Lobe center angle will not be altered by any means.
- D. Lobe profile will not be altered in any way.



## **CAMSHAFT SPECIFICATIONS**

### **INTAKE**

Heel to Heel 0.864" - 0.869"  
Heel to Peak 1.079" - 1.093"

### **EXHAUST**

Heel to Heel 0.865" - 0.870"  
Heel to Peak 1.081" - 1.095"

Length - thrust flange to thrust flange: 3.135" minimum 3.142" maximum

Cam bearings are 0.547" - 0.551" and unaltered (under .547 minimum take out of service no DQ)

### **TAPPETS**

- A. Tappets must be stock Honda with no alterations.
- B. Base diameter: 0.909" minimum No maximum spec
- C. Stem diameter: 0.312 minimum
- D. Base thickness: 0.73" minimum 0.090" maximum
- E. Length: 1.220 maximum
- F. Weight: 16 grams minimum

### **Flywheel:**

- Minimum weight 1550 grams UT1 and UT2. 1525 gram minimum for UT3
- Minimum diameter 6.285"
- Minimum Thickness 1.465"

***Tech officials have the right to tech any or all cars in any class at their discretion. Tech Officials follow the same chain of command as all officers of QMA – as follows: Local/Regional – National. I.E.; Regional tech officials can tech at any event at their region and National Tech Officials can tech at any event in QMA. National Tech Director is final authority on all tech issues.***

### DECIMAL EQUIVALENTS OF NUMBER SIZE DRILLS

No.	Size in Decimals	No.	Size in Decimals	No.	Size in Decimals	No.	Size in Decimals
1	.2280	21	.1590	41	.0960	61	.0390
2	.2210	22	.1570	42	.0935	62	.0380
3	.2130	23	.1540	43	.0890	63	.0370
4	.2090	24	.1520	44	.0860	64	.0360
5	.2055	25	.1495	45	.0820	65	.0350
6	.2040	26	.1470	46	.0810	66	.0330
7	.2010	27	.1440	47	.0785	67	.0320
8	.1990	28	.1405	48	.0760	68	.0310
9	.1960	29	.1360	49	.0730	69	.0292
10	.1935	30	.1285	50	.0700	70	.0280
11	.1910	31	.1200	51	.0670	71	.0260
12	.1890	32	.1160	52	.0635	72	.0250
13	.1850	33	.1130	53	.0595	73	.0240
14	.1820	34	.1110	54	.0550	74	.0225
15	.1800	35	.1100	55	.0520	75	.0210
16	.1770	36	.1065	56	.0465	76	.0200
17	.1730	37	.1040	57	.0430	77	.0180
18	.1695	38	.1015	58	.0420	78	.0160
19	.1660	39	.0995	59	.0410	79	.0145
20	.1610	40	.0980	60	.0400	80	.0135

- END-